

ITER CTA NEWSLETTER

No. 2, OCTOBER 2001

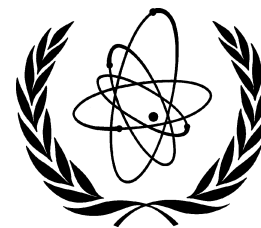

INTERNATIONAL ATOMIC ENERGY AGENCY, VIENNA, AUSTRIA

ISSN 1024-5642

RESULTS OF THE ITER TOROIDAL FIELD MODEL COIL PROJECT

by Drs. E. Salpietro and R. Maix, ITER EU Home Team, Garching

In the scope of the ITER Engineering Design Activities (EDA) one of the Seven Large Projects was devoted to the development, manufacture and testing of a Toroidal Field Model Coil (TFMC). In an article in the ITER EDA Newsletter, Vol. 6, No. 4, April 1997 (R. Thome, N. Mitchell, E. Salpietro, R. Maix, "Toroidal Field Model Coil Project") the layout and first manufacturing steps of the TFMC as well as the project organization were described. The industry consortium AGAN (Accel, Ansaldo, Alstom, Noell) manufactured the TFMC based on a conceptual design developed by the ITER EDA European Home Team. The TFMC was completed at the end of 2000 and was assembled in the test facility TOSKA of the Forschungszentrum Karlsruhe in the first half of 2001. The first testing phase started in June 2001 and lasted till October 2001.

The main goals of the project were:

- to develop and verify full scale TF coil manufacturing techniques,
- to establish realistic manufacturing tolerances,
- to benchmark methods for the ITER TF coil acceptance tests,
- to gain information on the coil's mechanical behaviour and operating margins

Therefore the racetrack shaped TFMC took over as many as possible full scale design features from the ITER TF Coil design. The winding pack is built up of five double pancake modules made of an insulated Nb₃Sn cable in conduit conductor, impregnated and then embedded in 316LN stainless steel radial plates (Figs. 1 and 2). Only the overall size (~1:3.5) had to be chosen in order to fit the TFMC together with the EURATOM Large Coil Task (LCT)* coil into the existing large cryogenic test facility TOSKA of the Forschungszentrum Karlsruhe (Fig. 3).

The winding pack is insulated and impregnated with epoxy resin and surrounded by an 80 mm thick steel case also of 316LN. For the cooling and monitoring of the TFMC, the helium header systems including the insulating breaks and a large number of sensors were assembled on the coil. Two superconducting NbTi busbars were mounted to the winding terminals and aligned for meeting the interfaces of the TOSKA facility. Electric and hydraulic acceptance tests were performed before the coil left the factory.

MANUFACTURE

A number of new technical methods and related tooling had to be developed in industry in order to be able to complete the manufacture of the TFMC successfully. Some of them are listed below:

- Manufacture of Nb₃Sn strands using the internal tin technique,
- Conductor cabling and jacketing with a circular 316LN stainless steel tube,
- Fabrication of the conductor terminations to provide a low resistance for the transfer of the current between pancakes and double pancake modules,

* In the scope of the Large Coil Task six toroidal coils were developed and built by US, European and Japanese institutes and industries to a common performance specification. They were tested in a toroidal arrangement in 1986 at the Oak Ridge National Laboratory. This was the first proof of feasibility of such large coils.

- Winding into stainless steel moulds and reaction heat treatment at 650°C with a 200 h plateau to form the superconducting intermetallic compound Nb₃Sn in the strands,
- Insulation and transfer into the grooves of radial plates and laser welding of the covers,
- Stacking of double pancake modules and electron beam welding of the outer joints,
- Insulation and impregnation of the large winding pack (Fig. 4) and assembly with the case,
- Manufacture and assembly of the header system and the NbTi busbars,
- Manufacture of the Inter-Coil Structure (ICS) and its assembly with the TFMC,
- Assembly of the TFMC/ICS with an auxiliary structure in the TOSKA facility.

A detailed test programme has been elaborated. After cooldown and acceptance tests, the electromagnetic, thermo-hydraulic, mechanical and dielectric insulation properties are being explored in two phases. First the TFMC was tested alone till Oct. 2001. It will be assembled and tested in 2002 together with the LCT coil in order to explore fully the operational limits of conductor and coil.

PREPARATION FOR THE TESTING OF THE TFMC

Assembly of TFMC/ICS in the TOSKA facility

After initial tests to verify that the coil suffered no damage during transport, the TFMC was assembled with the ICS and then with the auxiliary structure which replaced the LCT coil in the first testing phase.

Before the assembly was lifted into TOSKA, the first part of the so-called warm acceptance test was performed. This comprised various DC and AC high voltage tests between conductor and radial plates, between radial plates and between coil and ground, and the check of all sensors.

After the assembly was lifted into TOSKA, the hydraulic circuits were provisionally connected in order to allow a thorough leak test of the whole system under vacuum. The leak test showed a leak on one Gyrolock joint used for a temperature sensor, which had to be removed and sealed.

The 80 kA current leads were mounted to the facility and SC busbars No. 1 (conductor end winding – intermediate joint) were connected to SC busbars No. 2 (intermediate joint – current lead) and insulated. Busbars No. 1 were preshaped in the supplier's works based on exact measurements by ENEA with a laser tracker system of the interfaces of the ICS, busbar No. 2 terminations, the TOSKA vessel and the TFMC at the supplier's works. Thanks to this only a small correction was necessary during final installation in TOSKA. All hydraulic pipes were connected to the cooling system and low voltage and high voltage sensor cables were routed to the feedthrough boxes.

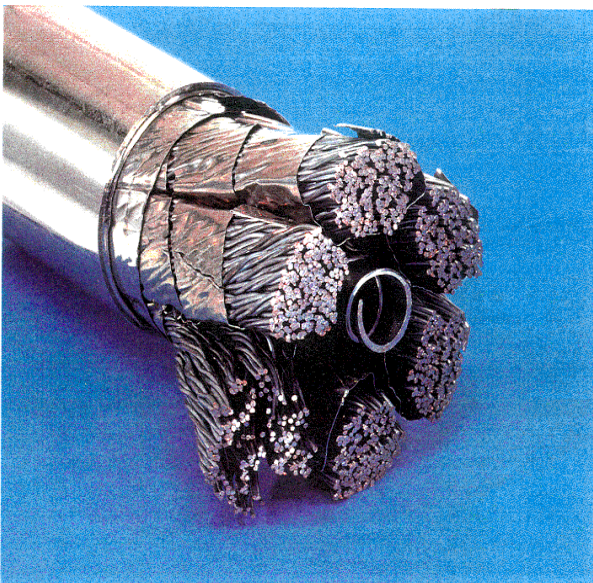

Fig. 1: TFMC conductor: 720 Nb₃Sn and 360 Cu strands cabled around a centre spiral and inserted in a 316LN jacket

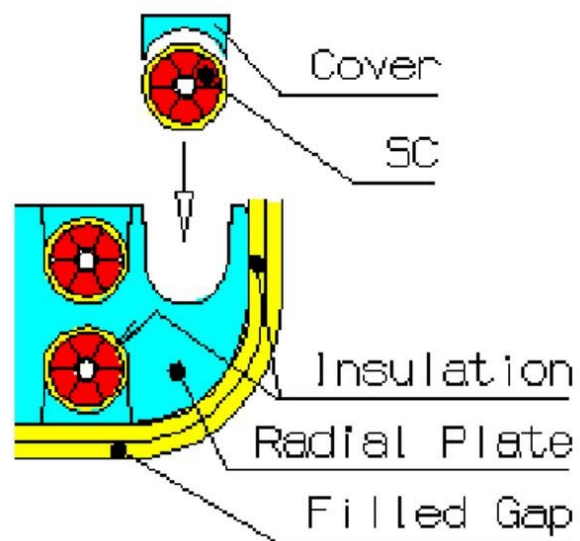

Fig. 2: The conductor is insulated with glass/Kapton tapes and is placed inside the groove of the radial plate

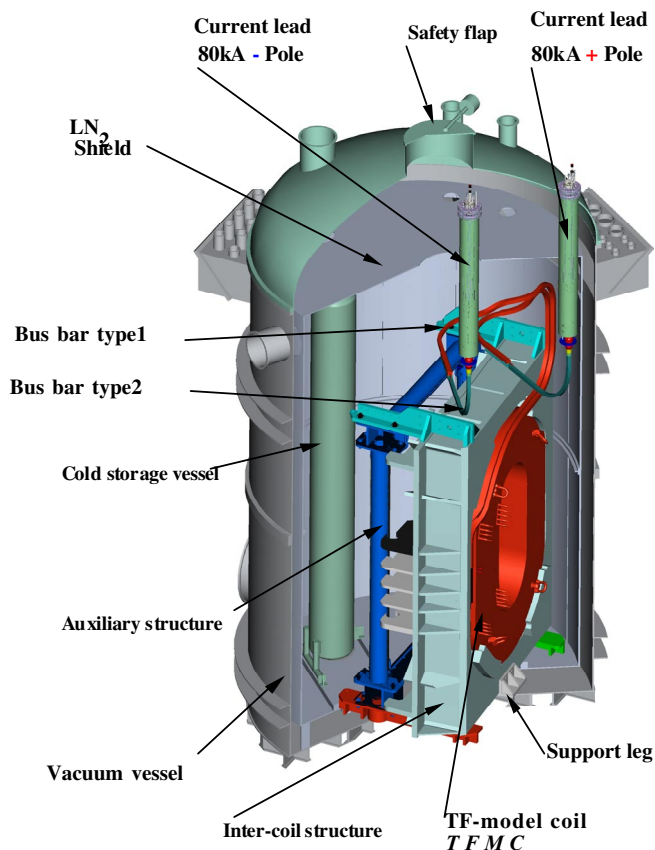

Fig. 3: The test rig to test the TFMC alone in the TOSKA facility of the Forschungszentrum Karlsruhe



Fig. 4: The impregnated winding pack consisting of five double-pancake modules

Cooldown

The coil was cooled down at a rate of 1 K/h in two weeks respecting the set temperature margins. Some temperature sensors of the ICS had to be excluded from the control loop in order to maintain the cooling rate. This was done based on the cooldown analysis in agreement with the manufacturer.

Acceptance tests

The function of the sensors, instrumentation and valves was checked. The flow distribution through the channels was measured. As expected from the pressure drop measurements during fabrication, the two side DP modules show about 10% higher mass flows than the three inner ones, which is due to the use of a cable centre spiral with a slightly different geometry. Scaling with pressure drop was found in good agreement with calculations. A leak rate of 2×10^{-5} mbar l s⁻¹ was measured at the operating temperature of 4.5 K, at 3.8 bar system pressure and 2×10^{-6} mbar vacuum vessel pressure.

The DC high voltage strength reached 10 kV at 4.5 K and 2×10^{-6} mbar vacuum vessel pressure, while the pulse voltage test reached 5–7 kV. Up to ten pulse tests at 4 kV for each polarity showed no breakdown. Therefore the safety discharge of the TFMC at a voltage of 535 V has sufficient margin.

FIRST TEST RESULTS

The TOSKA facility was operated very reliably. All operation conditions of the TFMC (cooldown, current tests, safety discharge, current sharing tests with heat loads far above the capacity of the refrigerator, and quench) were mastered successfully by the cryogenic, control and DAS system during the test period. During safety discharges or quenches no helium gas was released to the atmosphere and the recooling time was only around 2 hours. During all tests the vacuum remained stable at a pressure of 2×10^{-6} mbar.

The 80 kA current was well handled by the current leads and by the superconducting and water cooled busbar systems, as well as by the power supply system and the safety discharge circuit.

Current tests

The TFMC was ramped up in steps to 10, 20, 30, 40, 56.6, 69.3, 75.9 and 80 kA. Within one week of the acceptance tests, the TFMC reached 80 kA, which is the largest current ever put in such a large coil. Each step consisted of three times ramping up with 100 A/s followed by a discharge with the same ramp rate, an inverter mode discharge (max. voltage of the power supply) and a fast safety discharge. In the first test campaign the coil was repeatedly energized with 80 kA and withstood many safety discharges from currents larger than 50 kA. Several safety discharges were performed at 80 kA, some of them initiated by quenches created by a heated helium flow. No instabilities of the conductor were observed during the whole operation under current.

In the second test phase further high current tests are foreseen together with the LCT coil.

Joint resistances

The good performance of the inter-pancake joints is of highest importance in large superconducting coils, particularly at high currents. The applied joint design was developed according to a design of CEA and proven with two full size joint samples manufactured in industry and representative for the inner and outer TFMC joints. Tests in the SULTAN facility of CRPP in Switzerland showed resistances in the range of 1 to 2 n Ω . The joints consist of two explosion bonded copper-stainless steel boxes in which the two conductor ends are pressed with a force of 200 t, after removal of the petal wraps and the Cr-coating from the strands. The two boxes of the inner joints are soldered together with PbSn, while between the two boxes of the outer joints copper pins have been introduced, which were e-beam welded. Figure 5 shows the cross-section of a joint box and two adjacent inner joint boxes before soldering.

The TFMC joint resistances were determined by electrical and calorimetric measurement to be between 1 and 2 n Ω . Electrical measurements were performed mainly for the five inner TFMC high field joints. Within the measuring accuracy of about ± 10 μ V no time dependence of the resistance during long plateaus (30-100 minutes) could be detected.

The electrical measurements were confirmed by a calorimetric evaluation using the inlet temperature and the outlet temperature and the helium mass flow of the pancakes. With this method, it is possible to estimate the sum of one half inner joint and one half outer joint of each pancake by plotting the steady power dissipated in the circuit as a function of the square of the coil current. The slope of this curve then gives the pancake joint resistances.

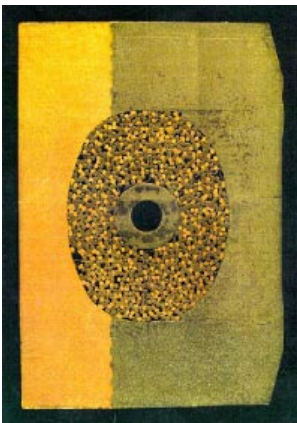

Fig. 5a:
Termination cross-section



Fig. 5b: Two adjacent terminations of a DP module inner joint before being soldered and clamped together

Thermo-hydraulic properties

The coil was operated first at 80 kA at a temperature of 4.52 K and a pressure of 5.0 bar at the inlet. No systematic change of the pressure drop was observed across the winding during operation under current.

After a safety discharge from 80 kA the following maximum temperatures were measured: 18 K in the winding, 21 K in the case and 12 K in the ICS; the global maximum pressure was limited to 7 bar. During re-cooling, 3.6 MJ were removed from the winding and 1.7 MJ from the case. In the case of quenches from 80 kA a backflow of helium occurred through the inlet having a maximum temperature of about 65 K.

Mass flow and pressure drop tests

Pressure drop tests were performed at zero current, at nominal 4.5 K and 5 bar. Both heater equipped pancakes P1.1 and P1.2 were tested. In each pancake the massflow rate was increased from ~4 g/s to ~20 g/s by increasing the rpm of the pumps and the regulation of the control valves.

The experimentally obtained flow rate data in both pancakes can be well reproduced (within $\pm 5\%$) and verified with the codes developed.

Heating tests

A calorimetric calibration of the heaters was performed before the heating tests. For massflow rates above 8-10 g/s, the power received by the helium is in good agreement (difference $\leq 10\%$) with the electrical power input.

Heating tests were performed at zero current for optimizing the heating power strategy for quenching the conductor, aimed at exploring the operational limits. A PC program generated the shape of the heater power pulses during ramp-up. A multistep strategy turned out to be a successful method. Other heater power pulses with ramped and trapezoidal heater power scenarios were also tested.

Measurement of the current sharing temperature (T_{cs})

Using the above-mentioned optimum scenario based on the multistep strategy, the first measurement of the T_{cs} at 80 kA was successfully performed. Initial conditions were of ~6.2 bar and ~4.5 K at the conductor inlet, and ~14 g/s in the heated channels. Just before the transition to normal, the power in each heater was ~300 W. The test ended with a quench of the coil, followed by the safety discharge. The normal zone was originated first in the P1.2 conductor, with an inlet helium temperature of about 8.6 K just before the quench, as expected from previous analysis. These tests were repeated several times at 80, 69.3 and 56.5 kA. After eight quenches and cyclic loads the T_{cs} remained unaffected.

Mechanical properties

The measured sensor values are compared with predicted values coming from the finite element model. All following calculated values assume a friction coefficient of 0.3.

The general behaviour of the displacement sensors corresponds well to the predicted values, but two of them did not work. At 80 kA the horizontal opening of the coil increased by about 1.5 mm (calculated: 1.7 mm) for 80 kA, while the vertical opening decreased by 0.8 mm (calculated: 0.65 mm). The joint region was elongated by 0.25 mm on the inner side (calculated: 0.25 mm) and 0.5 mm on the outer side (calculated: 0.5 mm).

The equivalent stresses measured with the rosettes are quite comparable with those predicted by the calculation. The maximum stress reached in the vertical plane is 130 MPa (calculated: 130 MPa). The maximum stress reached in the equatorial plane is 100 MPa (calculated: 80 MPa) on the outer side.

Behaviour of the NbTi busbars

The busbars were made of a cable in conduit conductor built up in a similar way to the TFMC conductor, but with 1152 NbTi strands having a Cu:NbTi ratio of 2.4 and an internal CuNi barrier. This conductor having a square 316LN jacket is nearly representative for the ITER PF conductors. The two busbars are each divided into two pieces. Busbars 1 lead from the coil terminations to the ports of the TOSKA vessel, while busbars 2 form the lower part of the current lead system. A de-mountable joint connects them to each other.

The busbar joints are made in a similar way to the TFMC joints. For the terminations the same boxes are used in which the conductor ends are pressed, the strands being silver coated and the copper sole being

indium coated. The contact surfaces of all terminations are either silver or gold plated. As the busbars are divided there are three different joints: the joint to the coil terminations is soldered, while the joints to the current leads use a highly compressed indium foil to make the contact. The inter-busbar joints have to be demountable. Therefore indium wires were compressed between the two terminations to connect them, as first used for the CS Model Coil Facility of JAERI, Naka, Japan.

The busbars have not been specifically tested up to now, because the main interest has been to explore the behaviour of the coil. Nevertheless the busbars have allowed the testing of the coil without problems and have in this respect fulfilled the expectations. As the busbar voltage is only monitored as a whole the individual resistances of the three types of joints cannot be determined. The voltage measurement covers the busbar intermediate joint and the two half-joints to the coil and the current leads. The total resistance derived amounts to 2.2 n Ω , which is in any case less than expected. The methods of fabricating the terminations and joining them can therefore be taken as a valid design for the ITER PF coils.

CONCLUSIONS

With the successful manufacture and first test campaign of the ITER TFMC, the main goals of the project have been achieved. The feasibility has been demonstrated and with the successful current tests up to 80 kA the design principles of the ITER TF coils have been confirmed. What remains in the further test programme is to explore the operational limits of the conductor and the coil, specifically also during the extended tests together with the LCT coil. This means besides the higher field levels a doubling of the mechanical stresses on the TFMC.

ACKNOWLEDGEMENT

The authors would like to thank all those who have contributed to the success of the project, the manufacturers, the ITER Joint Central Team and the members of the ITER EU Home Team.

CHARLES MAISONNIER, THE MAN AND THE FRIEND *

by Dr. E. Canobbio

Charles was a son of Lyon. Born on 8 October 1931, he was only 15 when he left, as first on the list, the de la Salle School, a rather peculiar school, as he used to say, which left enduring traces on him. At 20 he left the Ecole Centrale Lyonnaise, once again as first on the list. Then, at 25, he left the Ecole Supérieure des Télécommunications, second on the list; at the age of 35 he defended his doctoral thesis in physical sciences at Lyon University.

After a short time at Lyon University, he started his international carrier: in 1956/57 Berkeley and Brookhaven, with a Fullbright fellowship, and, after some time at CEA-Saclay, in 1959 CERN. In 1960, Charles Maisonnier entered Euratom, as a scientist at the Frascati Centre.

Charles' international scientific reputation rests with the 1 MJ Plasma Focus project he conceived and realized, as Laboratory Director, at Frascati. For this success, he received in 1968 the prestigious "Jean Thibaud Prize" for young physicists of the Lyon Academy.

Those were the golden years of plasma physics research. But Charles used to consider his "anni romani" primarily as a major experience of life. And it is perhaps in this "bouillon de culture" (culture medium) that seeds of his becoming later such a resourceful European civil servant are to be found.

It was in 1978 that he started his carrier in Brussels and he was 55 when, in 1986, he became the Director of the European Fusion Programme. He served in this position for about ten years, following in the steps of his great predecessor.

* This article is a reconstruction of a speech delivered by the author on the occasion of a Memorial Service for Dr. Maisonnier held on 19 September 2001 at the Eglise Sainte Anne, Brussels.

What he achieved during these years as the chief defender of the fusion heritage of the European Union is virtually common knowledge. But his forceful striving for “a single voice” in fusion policy matters within Europe and his capabilities in managing major crises – especially the ones that shook ITER and have led to the three co-centres and a change in the leadership of the project – actually belong to the realm of our history.

Rooted in Summit Meetings in the middle of the 1980s and joining together the efforts of the European Union, Russia, Japan and, except for the last period, the United States, the ITER venture was and still is the greatest challenge for the fusion community around the world. Charles Maisonnier’s role in ITER soon became outstanding. He was a much respected leader till his retirement in 1996.

Nominated afterwards Special Advisor to the Commissioner, he withdrew from his position in 1998, but continued to care about ITER and fusion, the world he never left. In the same year, 1998, the Lisbon Technical University made him Doctor Honoris Causa.

Struck down in 1995 by a disease he met stoically, and surrounded by his large family, who loved this paterfamilias dearly, as well as by the many friends he liked to receive so generously till the end, suddenly, on 27 July 2001, he passed away.

Now each of us is left with his own memories of Charles. I would like to share with you some of my memories of the friend I have lost.

I discovered Charles Maisonnier in 1985 on a train to Brussels, by chance, and I will never forget the engaging monologue by him there on the beauty of the structure of an old-time prison for life he once saw on a tiny Italian island.

I then had, over a period of twelve years, the privilege of working closely with him, and of accompanying him on many missions, as far as the shores of the Pacific Ocean. Sometimes it was hard work on texts, sometimes relaxing conversations on everything.

He was somehow sharp-cornered and charming at the same time, and entertaining. He was an upright man, open and incapable of hiding his nature.

On the many group pictures of the ITER Council meetings, Charles Maisonnier, conscious of his rank, is, of course, to be found in the front row. But, if one looks closely, one will discover, superposed on the dignified face of the leader, also the face of the schoolboy of Lyon.

He was a man of conservative instincts, with certainties, mitigated by realisms and some doubts, exigent, determined, responsible and vigorous.

To draft speeches for Charles was a rather discouraging duty as he actually followed the precept: “Read over your composition and wherever you meet a passage which you think is particularly fine, strike it out!”

He quoted once in a speech Seneca’s saying “consensus is proof of truth”. But, I think his democratic inclinations were more in line with St. Benedict’s Rule. And indeed one of his preferred quotations was: “When business of great moment has to be done in the monastery, let the abbot call together the whole community and himself set forth the matter. And having heard the advice of the brothers, let him take council with himself and then do what he shall judge to be most expedient.”

Charles seemed to possess the secret of friendship: the way to have a friend is to be one. He enjoyed so sincerely being with his friends at his beautiful house or around the table of a working party.

He could not harbour resentment and used to say something like: “It is no virtue, I have great memory for forgetting.”

In Bach’s music, perhaps, with Gregorian Chants, to which he was really vulnerable, Charles liked in particular those pieces following one another logically, elaborations of one and the same material and the peaceful, simple way of dying out Bach chose to close his masterpieces. I have the feeling that somehow these last words might also evoke the “well tempered” way Charles Maisonnier conducted his whole life.

Items to be considered for inclusion in the ITER CTA Newsletter should be submitted to B. Kuvshinnikov, ITER Office, IAEA, Wagramer Strasse 5, P.O. Box 100, A-1400 Vienna, Austria, or Facsimile: +43 1 2633832, or e-mail: c.basaldella@iaea.org (phone +43 1 260026392).

Printed by the IAEA in Austria
February 2002

02-00020